

TORSA



SHIMANO

INSTRUCTION GUIDE

Thank you for choosing Shimano!

We believe we have created the finest big game trolling reels in the world in our Shimano TORSA series. They are the result of years of engineering development time and thousands of hours of lab and field testing. We have pursued these reels' design and manufacture with the goal of embracing the romance and excitement of big game fishing and combining it with the advancements of technology. We hope you will enjoy the TORSA reels that you have purchased for many years to come. Once again, thanks.

RATCHETING DRAG ADJUST LEVER

RAPID FIRE QUICK CHANGE
DRAG CAM SYSTEM / PRE-SET KNOB

SUPER STOPPER
ASSIST STOPPER

ERGONOMIC RUBBER GRIP
WITH TWO BEARING SUPPORT

CLICKER SWITCH

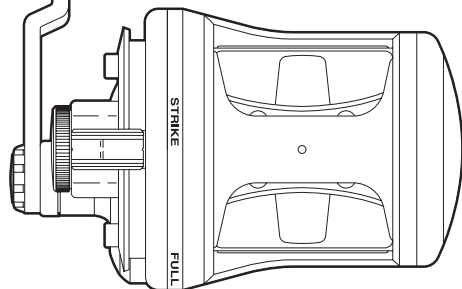
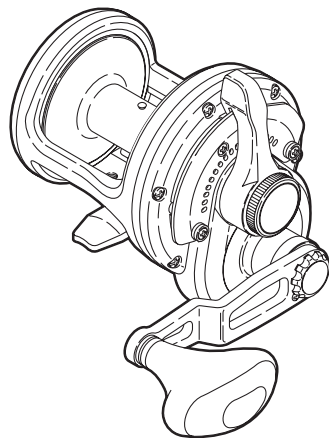
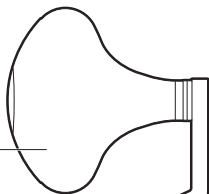
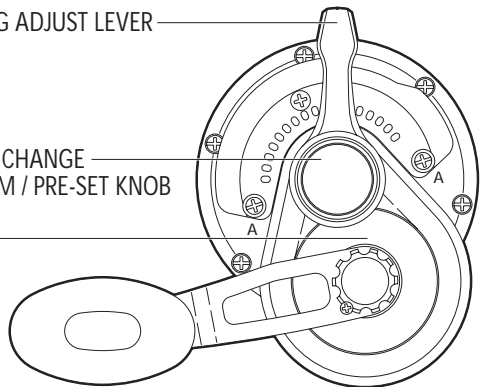

Model No.	Weight (g/OZ)	Gear Ratio	Ball Bearing /Roller Bearing (A-RB)	Mono Line Capacity				
				#14Lb. (Yds)	#16Lb. (Yds)	#20Lb. (Yds)	#25Lb. (Yds)	#30Lb. (Yds)
TORSA 16N	812/28.6	5.8:1	8/1	300	270	200	/	/
TORSA 16	824/29.1	5.8:1	8/1	/	450	320	/	/
TORSA 20	845/30.2	5.8:1	8/1	/	/	420	300	/
TORSA 30	871/31.1	5.8:1	8/1	/	/	/	420	350

TORSA REELS ARE PROTECTED BY THE FOLLOWING PATENTS

MODEL

U.S.A. PAT. No.

TORSA-16N/TORSA-16/TORSA-20/TORSA-30

6045073, 4742974

Pre-set & drag curve relationship . . .

Undoubtedly, the main reason for using a lever drag reel is superior drag performance. Lever drag reels, by the nature of the design, have greater drag surface area than star drag reels. This allows them to run cooler, last longer, and perform better.

TORSA reels have been optimized for big game lines. We recommend that the strike position be 25% to 33% of the line's rated breaking strength. As an example, for 20 lb. test, the drag should be between 5 lbs. and 7 lbs. On 30 lb. test, the drag should be between 7.5 and 10 lbs. Once the reel has been set up properly each reel will have an absolute difference between the strike and full position.

	Reel Optimized for (#test in mono)	Strike @ 33% of Line Break Strength	Full @ 33% of Line Break Strength	Absolute Difference
TS16N	14	5	8	3
TS16	16	5	9	4
TS20	20	7	11	4
TS30	30	10	18	8

(The difference between strike and full can vary slightly from reel to reel. Please check you reel with a scale to be certain.)

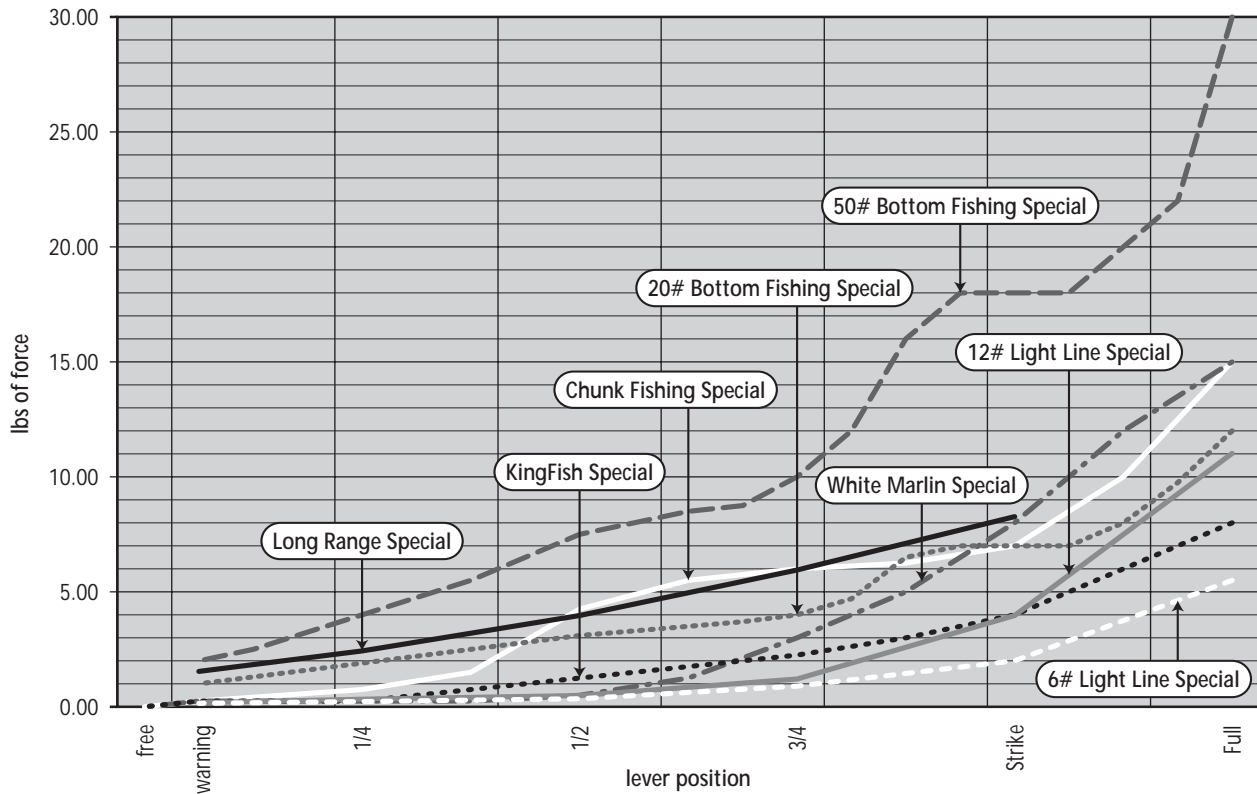

•These curves illustrate the drag force when used with recommended drag and line settings. They are not maximum drag settings.

Setting the drag . . .

Always make pre-set adjustments with the lever in the freespool position. This is primarily because the pre-set will be extremely difficult to turn when the drag lever is engaged in the strike position.

Our research has shown that all drags are sensitive to changes in speed (acceleration). Once the speed remains somewhat constant, the drag will return to pre-set levels. We recommend that you pull line off the reel at a speed approximating the target species' speed when setting your drag. We have clocked a Blue Marlin at a top speed of 34 km/hr (21 mph) from a boat at 6-7 knots (though it was for less than a full second).

To give you an idea of how fast that is, a fish running at 21 mph would spool an 80W in approximately 90 seconds.

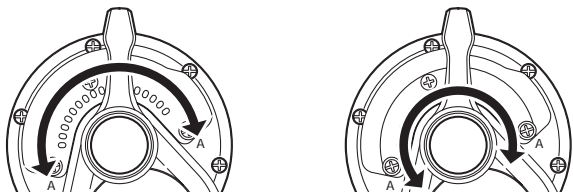

Scaling the drag . . .

All big game fishing reels should have the drag set using a drag scale for maximum accuracy. When setting the drag, the line should be set up on the rod through the guides, and the line should be pulled off so the blank of the rod is loaded, as when fighting a fish. Pull the line off at a speed approximating the target species' speed.

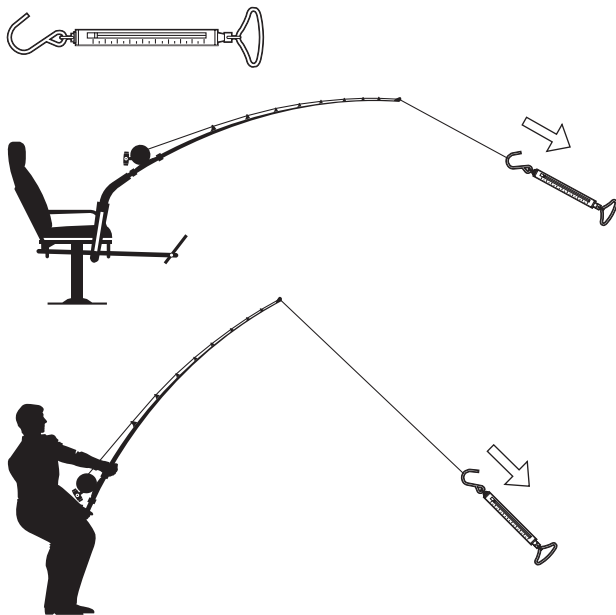

Effects of heat . . .

The lore of big game fishing is replete with stories of smoking reels dripping oil and grease. Occasionally it still happens today. And, traditionally, it has been known that drag force tends to increase with the increased reel heat. Heat can cause the drag to increase by the simple expansion of the related parts. The expanding parts have nowhere to go, and therefore exert greater forces on each other.

While this is true in many cases, some newer reels have drags that do exactly the opposite. Some graphite (or carbon fiber) drag washers have a physical quirk that causes the drag force to decrease with heat. The nature of the surface friction changes when the drag surfaces get hot; and the drag gets slicker. In reels where the friction change (decreasing drag) happens faster than the parts' expansion (increasing drag), the net drag force will decline.

Drag to line level relationship . . .

Another cause of drag variance is the line level on the spool. Drags are generally set when the spool is filled. When the spool is filled, the line will pull off the edge of the spool. When the line level is reduced, the "leverage" that the line has on the spool is reduced. Therefore, a greater force must be applied to the line in order to move the spool against the drag.

The TORSA 20 has a 29.75 mm (top of) spool radius and a 11.00 mm arbor radius. The line level drag difference when virtually all the line is gone will be 2.7 times the original setting. If your original (top of spool) strike drag was 7 lbs., then the bottom of spool strike drag will be 19 lbs.

The TORSA 30 has a 29.75 mm (top of) spool radius and a 11.00 mm arbor radius. The maximum line level drag difference will be 2.7 times the original drag setting. If the original (top of spool) strike drag was 10 lbs., the bottom of spool strike drag will be 27 lbs.

For all TORSA reels, the drag force will be doubled when approximately 75% of the full spool is off the reel.

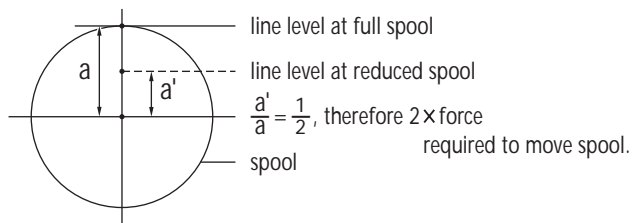

Drag testing . . .

We have subjected TORSA reels to a variety of lab tests, to gather data on drag performance, drag durability, mechanical performance and mechanical durability. With this data we have learned a great many things about the nature of drags.

While our main drag durability test gives us a good indication of the drag wear and durability, we've found that there are many external factors that can affect drag performance. The ambient temperature of the room, speed of the wind, presence of water on the line, length of fish runs, and quantity of fish runs can all affect the drag performance. It is, literally, enough to drive you crazy.

Even though we attempt to create tests that duplicate actual fishing conditions, there is no substitute for "the real thing." However, we also need to gather data through actual fishing and angling performance. So we created a device that can measure drag force, line speed, and dispensed line quantity while a reel is hooked up to a live hard fighting fish. Then we put some thermal tape on the spools to measure the heat build up and sent the reels fishing.

Over time, we have managed to gather data on fish ranging from Striped Marlin to (est.) 600 lb. Blues. We are not aware of any previous tests that obtained the real-time, actual fish data like this. And it has helped us fine tune the performance of our reels to actual fishing conditions.

Experienced game fishermen know that big fish are definitely more punishing than medium or small fish. The quantity and length of runs do more to heat up the reel than the amount of time hooked up. And, big fish run longer and more often.

Filling the spool . . .

When filling the spool, be sure to tie the line onto the arbor pin. Forgetting to do so may allow the line to slip around the spool under pressure.

We recommend you fill the spool to the line etched into both sides of the spool. Filling the spool beyond that may cause you to experience difficulty levelwinding while fighting a fish.

Mounting on rods . . .

One of the most convenient TORSAs features is the rod clamp screw. They can be installed on the reel after the spool has been filled with line. You'll see that the sides of the screw heads have been trimmed. This enables you to put the screw in the reel foot opening, turn it 90 degrees and your ready install the lock nuts. Then mount the reel on the rod with the clamp and screws.

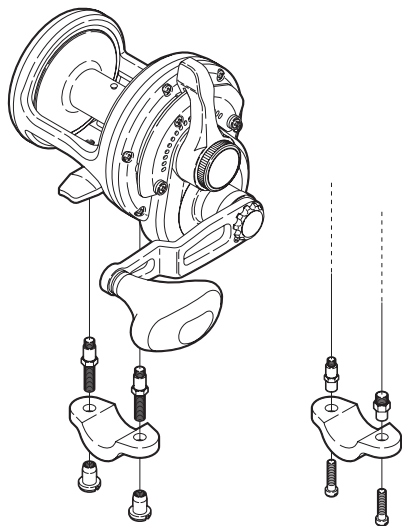

20, 30

16, 16N

Clicker operation . . .

The TORSAs's clicker has been designed to be as loud as possible without impeding the reel's performance. The clicker is on when the switch is "in."

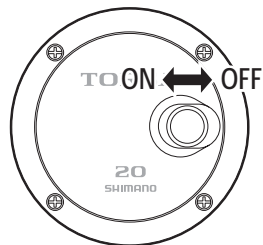

Super Stopper . . .

Super Stopper anti-reverse uses a one-way stainless steel roller bearing to eliminate backplay. It helps you drive the hook immediately upon hook-set.

In addition, the TORSAs features Assist Stopper, a backup anti-reverse pawl to ensure zero failures.



ASSIST STOPPER

Maintenance . . .

Your Shimano reel is designed to provide years of dependable performance when properly maintained and lubricated. Exercise care when lubricating. Excess grease and oil can flow into places where it might hinder the performance of the reel. On most parts, only a light coat grease or a few drops of oil are required.

To clean after each use, rinse the reel under a light mist of warm water. This will rinse away dirt and breakdown salt before it deposits onto the reel. Dry the reel with a soft cloth. Next, spray a water-displacing lubricant or synthetic protectant onto a soft dry cloth. Rub evenly onto the reel to spread a thin protective layer of lubricant. (Do not spray the lubricant directly onto the reel as it can penetrate into the inner workings and breakdown any grease or oil required in maintaining the reel's functionality.) Shimano recommends that your reel be professionally cleaned and lubricated at least once a year by a Shimano Satellite Service Center in your area.

Ordering parts & repair . . .

Ordering parts

When ordering replacement parts, always give the model number, part number and description. Mail this to your nearest Shimano Satellite Service Center. If available, the part will be delivered on a C.O.D. basis.

Repair

Shimano's Satellite Service network is ready to repair and service all of your Shimano fishing reels. We highly recommend you refer any servicing and regular maintenance to a Shimano Satellite Service Center in your area. Each center is fully empowered to inspect, clean, lubricate, and make all necessary repairs, including warranty repairs. When returning a reel for service; pack the reel in a sturdy package with adequate padding. Enclose a note containing your name, address, daytime and evening phone number, email address, and a brief explanation of problem or type of service requested. For warranty repairs, also include a copy of your dated sales receipt. Ship it, insured, to your local Shimano Satellite Service Center (we recommend using a carrier who will provide you a tracking number). For a complete list of Shimano Satellite Service Centers you can visit us on the web at www.shimano.com or call our Customer Service Representatives toll free at 877-577-0600.



Pack it well.

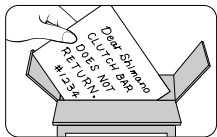

Tell us the problem.

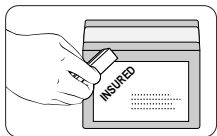

Insure and ship.

Warranty . . .

Shimano warrants to the original purchaser that this product will be free from non-conformities in material or workmanship for the period of one year from the date of purchase. **Please keep your receipt for all warranty claims.** To request warranty repairs (or non-warranty service) send your reel, postage pre-paid, to the Shimano Satellite Service Center nearest you. Retailers and wholesale outlets are not required or authorized to perform warranty repairs or exchanges on behalf of Shimano, nor are they authorized to modify this warranty in any way. In the case of warranty repair requests (**within 1 year of purchase date**). A dated sales receipt must accompany the warranty claim. Please follow the shipping instructions outlined in the REPAIR section of this document.

Please fill out the enclosed registration card so that we may better meet your needs.

Shimano . . .

Shimano's fine fishing tackle carries on a tradition of quality and pride started in 1921 with Shimano's first product, a bicycle freewheel. That same tradition of quality and pride is in every product Shimano manufactures; cold forging, bicycle components, fishing tackle, and the future.

Shimano Cares . . .

Literature and packaging included with this product is recycled and recyclable. Please return it to a suitable recycling facility.



To respect the environment
SHIMANO uses recycled paper.
Please do not litter.
This is a recycleable paper product.

SHIMANO SATELLITE SERVICE CENTERS

(U.S.A)

To receive the location of the nearest authorized warranty center to you please visit us on the internet at <http://www.shimano.com>, call us toll free at **(800) 833-5540** for an automated touch tone listing, or call **(877) 577-0600** 8-5 PST to speak directly to a service representative.

(Canada)

Québec, Maritimes

- Service Shiman-Au-Peche Inc.
9490 Transcanadienne
St.Laurent, Quebec H4S 1R7
Tel:(514) 956-9695
Fax:(514) 956-0181

- Eric's Reel Shop (reels only)
16 Osborne Avenue
Dartmouth, Nova Scotia B2W 1H8
Tel:(902) 463-8758

Ontario

- Classic Sports of Canada Ltd.
655 The Queensway; Unit #9
Peterborough, Ontario K9J 7M1
Tel:(705) 741-0636
Fax:(705) 741-2718

- A. Aikman Sporting Goods & Repair
3010 Novar Road
Mississauga, Ontario L5B 1S4
Tel:(905) 277-3595
Fax:(905) 277-0088

Manitoba, Saskatchewan

- Jaycee's Rod & Reel Repair
547 Vaughan Avenue
Selkirk, Manitoba R1A 0T2
Tel:(204) 482-7477
Fax:(204) 785-8255

Alberta, British Columbia, Yukon & Northwest Territories

- Gerry Scott Agencies, Ltd.
1952 Kingsway Avenue; Suite #406
Port Coquitlam, British Columbia
V3C 6C2
Tel: (604) 464-9344
Fax: (604) 464-9301

SHIMANO

SHIMANO AMERICAN CORPORATION

One Holland, Irvine, CA 92618 U.S.A. Phone: +1-877-577-0600

SHIMANO CANADA LTD.

685 The Queensway, Peterborough, Ontario K9J 7J6, Canada Phone: +1-705-745-3232

SHIMANO EUROPE FISHING HOLDING B.V.

Industrieweg 24, 8071 CT Nunspeet, The Netherlands Phone: +31-341-272222

DUNPHY HOLDING PTY. LTD.

UNIT1, Block A, 1-3 Endeavor Road, Caringbah, NSW 2229, Australia Phone: +61-2-9526-2144

SHIMANO (SINGAPORE) PTE. LTD.

20 Benoi Sector, Jurong Town, Singapore 629852 Phone: +65-6265-4777

SHIMANO INC.

3-77 Oimatsu-cho Sakai Osaka 590-8577 Japan Phone: +81-72-223-3467

Printed in Japan/Imprimie en Japon/Impreso en Japón



(050224)